

*Ammarr*<sup>®</sup>

***4300 Rolling Grille  
Installation Instructions***





## Section 1 - Table of Contents

|  |           |
|--|-----------|
| <b>Section 1 – Safety Check List</b>                                       | <b>2</b>  |
| <b>Section 3 –Freight Receiving</b>  | <b>3</b>  |
| <b>Section 4 – Pre-installation</b>  | <b>4</b>  |
| <b>Section 5 – Guides</b>  | <b>5</b>  |
| <b>Face of Wall Units Mounting to Wall</b>                                 | <b>5</b>  |
| <b>Face of Wall and Between Jamb Units Mounting to Free-Standing Tubes</b> | <b>7</b>  |
| <b>Between Jamb Units Mounting to Wall</b>                                 | <b>11</b> |
| <b>Mixed Guides</b>  | <b>12</b> |
| <b>Section 6 – Barrel and Brackets</b>                                     | <b>14</b> |
| <b>Preparation</b>   | <b>14</b> |
| <b>Ring Attachment</b>   | <b>15</b> |
| <b>Bracket Preparation</b>   | <b>16</b> |
| <b>Hoisting and Installing Barrel Assembly</b>                             | <b>17</b> |
| <b>Section 7 - Motor Operator Installation</b>                             | <b>19</b> |
| <b>Section 8 - Curtain Installation</b>                                    | <b>20</b> |
| <b>Applying Spring Turns</b>   | <b>21</b> |
| <b>Section 9 – Hood Support Installation</b>                               | <b>22</b> |
| <b>Section 10 – Hood, Fascia, and Covers</b>                               | <b>24</b> |
| <b>Hood and Fascia</b>   | <b>24</b> |
| <b>Covers</b>  | <b>26</b> |
| <b>Section 11 – Torque Specifications</b>                                  | <b>27</b> |
| <b>Section 12 – Maintenance Schedule</b>                                   | <b>28</b> |
| <b>Appendix A - Chain Sprocket Adjustor</b>                                | <b>31</b> |
| <b>Appendix B - Tube Motors</b>  | <b>32</b> |

## Section 2 - Safety Check List

Rolling doors are large, movable objects. They move with the help of electric motors or manual operators (chain, crank, push up, etc), and most have springs under high tension. These items and their components can cause injury. In order to avoid injury to yourself and others, please follow the instructions in this manual.

- Review the potential hazards and preventative measures listed below:

| Potential Hazard  |   | Preventative Measure   |
|---|---|--|
|    | <b>⚠ DANGER</b><br><b>Pinned or crushed by closing door.</b>                          | <ul style="list-style-type: none"> <li>• Keep yourself and others clear of opening while door is in motion.</li> <li>• Do not allow children to play near or operate door.</li> <li>• Do not operate if door becomes jammed or broken.</li> </ul>  |
|    | <b>⚠ WARNING</b><br><b>Struck by adjusting wheel bar while applying spring turns.</b> | <ul style="list-style-type: none"> <li>• Be sure bar is adequate in strength and long enough to allow installer to apply the necessary torque.</li> <li>• Make sure bar is fully seated into the adjusting wheel slot before applying pressure.</li> <li>• Use two bars while applying turns to the adjusting wheel.</li> </ul>  |
|   | <b>⚠ WARNING</b><br><b>Electrical shock.</b>  | <ul style="list-style-type: none"> <li>• Make sure electrical operator is properly grounded.</li> <li>• Turn off source power completely prior to servicing the motor.</li> <li>• Make sure wires are clear of any moving or potentially moving parts.</li> <li>• Avoid pinching wires when installing the motor cover.</li> </ul>   |
|  | <b>⚠ WARNING</b><br><b>Pinched by moving components.</b>                              | <ul style="list-style-type: none"> <li>• Make sure the motor is turned off and unplugged before working with moving parts such as roller chain and sprockets, drop-out mechanisms, adjusting wheels, etc.</li> <li>• Locate the possible pinch-points of the unit (Drive chain, coil area, bottom bar, etc.) Do not operate the door while someone is near these areas.</li> </ul> |

*Table 2.1 - Potential hazards and Preventative Measures*

- Check the following during installation and before leaving the job site:
  - a. If the unit has tension springs, be sure the proper amount of tension is applied to the torsion springs, in order to properly counterbalance the weight of the curtain.
  - b. Securely fasten the tension adjusting wheel in place with the appropriate hardware provided.
  - c. Check that the keys and/or cotter pins have been set in place and fit properly at all sprockets or gears.
  - d. Check that the setscrews in each sprocket or gear (one over the key and one offset from the key) have been tightened properly.
  - e. Check all fasteners holding the unit to the building structures.
  - f. Check all fasteners used to assemble the components of the unit together.
  - g. Instruct owner or representative in the proper method of operating the door.

### Section 3 - Freight Receiving

- **Upon delivery, check condition of components for damage.**
- **If damage occurred in transit, the installation should not proceed without authorization.**

#### **NOTICE**

If the installation proceeds, neither the carrier nor the manufacturer will assume responsibility for replacing the damaged material.

- **If the installation is stopped due to damage, do the following:**
  1. Take pictures of the damage.
  2. Do not move material from point of delivery to other premises once the damaged components are discovered.
  3. Do not unpack, if the damage is visible prior to removing packaging, until an inspection is made.
  4. If the damage is found while removing contents from packaging, the packaging material must be saved until inspection is made.
  5. Container and packaging should be retained by consignee until inspection is made.
  6. Have components inspected by carrier's representative within 15 days from date of delivery.
  7. Consignee must obtain a copy of the Inspection Report.
- **Returning damaged components:**
  1. Obtain permission from carrier to return.
  2. Route the return shipment via the identical carrier(s) involved in the original shipment.
  3. Notify the manufacturer when shipment is returned to manufacture plant.
- **Verify that all components have arrived. Look for the following:**
  1. Job construction drawings featuring different views (elevation, section, plan, etc.)
  2. (2) Guide assemblies; check for guide weathering if included in order
  3. Barrel assembly
  4. Curtain assembly with bottom bar attached
  5. (2) Bracket assemblies
  6. Operator; if not attached to bracket
  7. Operator cover; may not be included in order
  8. Adjusting wheel; if the barrel assembly contains springs
  9. Inertia brake; typically on units with springless barrel assemblies
  10. Hood and hood supports; may not be included in order
  11. Hardware
  12. Misc. items (Reelite, lintel seal, hood baffle, etc.)
  13. Verify material/finish/color of components matches what is listed on the job construction drawings and/or what was ordered.
- **If the delivery is incomplete:**
  1. Make note on delivery receipt.
  2. Note should be verified by driver's signature.
  3. Notify carrier and manufacturer.

## Section 4 - Pre-Installation

- **Read entire instruction manual thoroughly. The manufacturer will not be held responsible for any charges incurred due to improperly installed components.**
  - a. Only trained door systems technicians should perform installation, maintenance, etc.
  - b. Each unit comes with an individual item number. If the job contains multiple units, be sure to locate all the components for each item and separate each.

### **⚠ WARNING**

**Do not** interchange parts from one door to another.

- c. Find the job construction drawings for the unit being installed and check the dimensions of the opening against those on the drawings. See **Figure 4.1** below.
- d. If the opening dimensions differ from those on the drawings, **do not proceed**, check with distributor/manufacturer to be sure the correct door is being installed.
- e. Check the jambs of the opening for plumb. Check the head/lintel and floor for level. If the unit is to be free standing, for example mounted to tubes, check the floor and ceiling for level and for adequate mounting areas at the top and bottom.

*Note: The floor may not be level if a pitched bottom bar is specified.*

- **Work Area:**
  - a. The key to a smooth installation is a clean and well-prepared work environment. Once the components have been inspected and the job construction drawings have been reviewed; lay out the components in the order of installation.
  - b. The opening for the door should be cleaned and inspected for rough surfaces and construction debris.
  - c. Lastly the mounting hardware supplied with the door should correspond with the surface and construction features of the opening.
  - d. The basic assembly sequence is as follows: guides, barrel w/ rings or tapped holes, brackets, motor operator (if applicable), curtain, bellmouth, stoppers, weather stripping, hood, and operator/adjustor/idler covers.

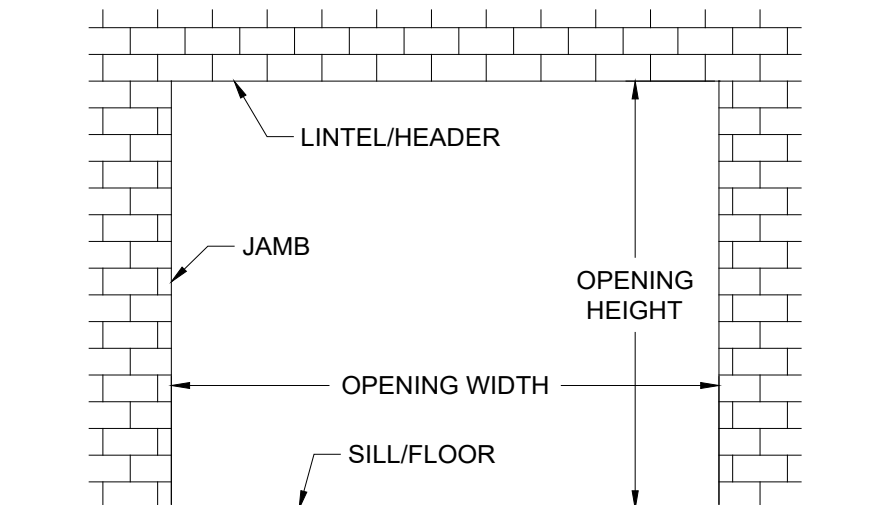
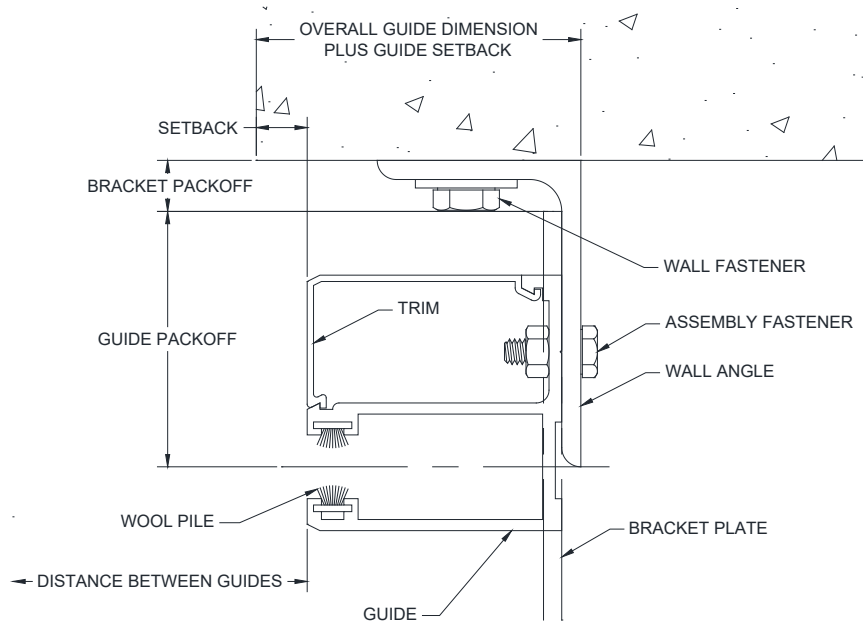

*Figure 4.1 - Opening Dimensions and Designations*

## Section 5 - Guides

### ▪ Face of Wall Units Mounting to Existing Wall Construction (Figures 5.1 - 5.2):

**Note:** Determine which guide assemblies are utilized on the unit from the job construction drawings and compare to the diagrams below.<sup>1</sup>



**Figure 5.1 – Face of Wall “E” Guide**

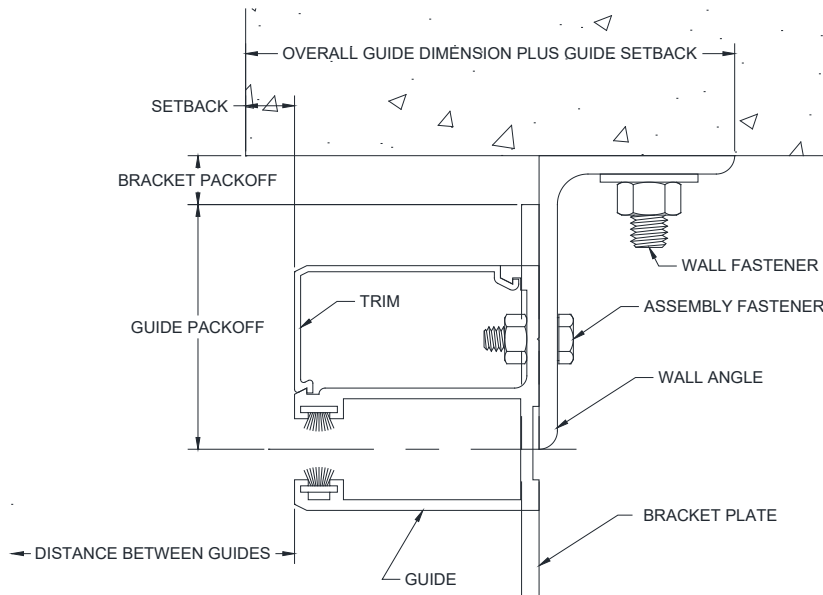

**Figure 5.2 – Face of Wall “Z” Guide**

<sup>1</sup> The guide assembly may differ from the right to left hand side of the unit. In these cases, follow the directions for each particular guide assembly, as well as the job construction drawings provided with the unit.

## Section 5 - Guides

1. Separate the trim and guide from the wall angle if necessary.
2. Measure the distance from the opening/jamb to the heel of the wall angle (on “E” guides) or the toe of the wall angle (on “Z” guides). This distance is referred to as the “*Overall Guide Dimension plus Guide Setback*”; see **Figures 5.1** and **5.2**. See the job construction drawings for the guide setback and overall guide dimensions.
3. Place mark on the floor at measured location. Check the distance between these marks and compare with the job construction drawing. It will be the “*Opening Width*” plus the “*Overall Guide Dimension plus Guide Setback*” at both jambs.

### NOTICE

If the measurement does not equal the dimensions on the job construction drawings, **STOP**. Check the guide dimensions against those on the job construction drawings to be sure the correct guides are being installed. If so, repeat previous step and re-check.

4. Scribe a plumb line on the wall from the marks on the floor.
5. Place the wall angle against the scribed line, check the top of the guide for level, and mark the location of the wall fastener mounting holes.
6. If the wall angle is attached to the wall with fasteners, drill mounting holes for the wall fasteners and fasten the wall angle with the hardware provided. Check the job construction drawings for the required wall fastener. Tighten the wall fasteners to the recommended installation torque in the *Torque Specifications Tables* in **Section 11**.
7. If the guide is attached to the wall by welding to structural steel, see the job construction drawings for details on weld location, type, pitch, size, etc.<sup>1</sup>
8. At this point, the aluminum guide extrusion can be reassembled to the wall angle using the hardware provided. It is not necessary to snap the trim into place at this time. Tighten to the recommended installation torque in the *Torque Specifications tables* in **Section 11**.

**Note:** You may find that delaying the installation of the aluminum guide extrusions until after the curtain is installed may alleviate the curtain installation process. This is a matter of preference, and will not affect the final product. If this is the case, set the guide extrusions, trim pieces and hardware aside until after the curtain is installed.

---

<sup>1</sup> Minimum recommended weld rod: AWS A5.1, Grade E-70.

## Section 5 - Guides

- **Face of Wall and Between Jamb Units Mounting to Free-Standing Tubes (Figures 5.3 - 5.4):**

**Note:** Determine which guide assemblies are utilized on the unit from the job construction drawings and compare to the diagrams below.<sup>1</sup>

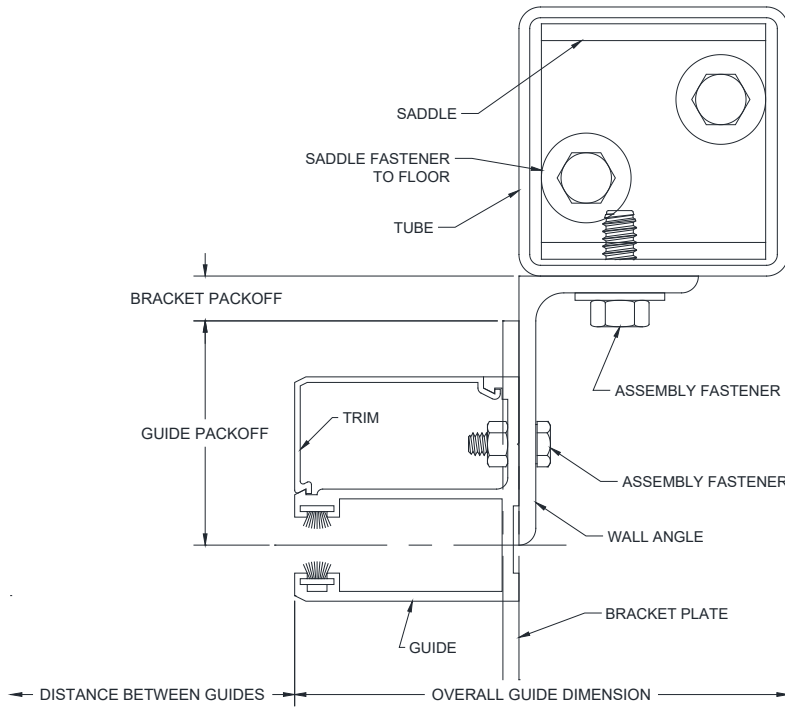

**Figure 5.3– Face of Wall “Z” Guide Mounting to Tube**

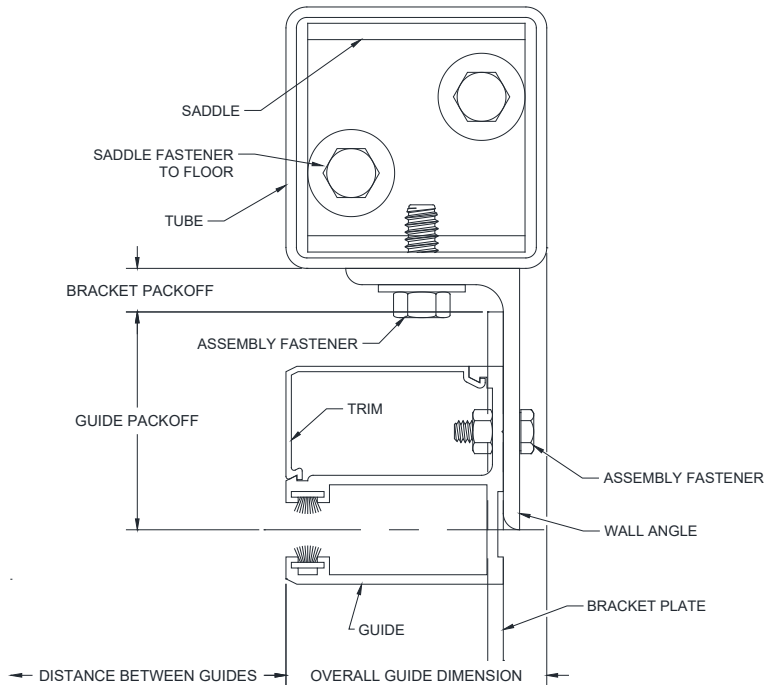

**Figure 5.4 – Face of Wall “E” Guide Mounting to Tube**

<sup>1</sup> The guide assembly may differ from the right to left hand side of the unit. In these cases, follow the directions for each particular guide assembly, as well as the job construction drawings provided with the unit.

## Section 5 - Guides

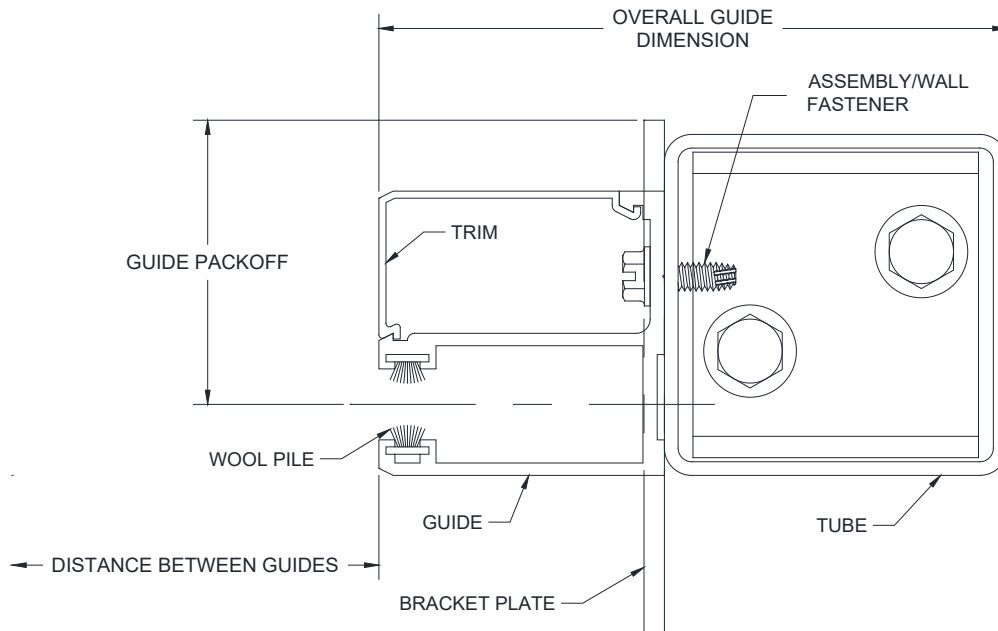

**Figure 5.5 – Between Jamb Mounting to Free-Standing Tube**

1. Separate the trim pieces, aluminum guide, structural tubes (and wall angles) if required.
2. Refer to the job construction drawings to determine the specified mounting tube location. Measure and mark the location of the mounting tubes.
3. Check the distance between these marks and compare with the job construction drawing. It will be the “Opening Width” plus the “Overall Guide Dimension” at both jambs.

### **NOTICE**

If the measurement does not equal the dimensions on the job construction drawings, **STOP**. Check the guide dimensions against those on the job construction drawings to be sure the correct guides are being installed. If so, repeat previous step and re-check.

4. *Tube Saddles* are provided for installing free-standing tubes. Locate the tube saddles (brackets used to constrain the tube at the bottom). There are two types of saddles: *standard saddles* and *inverted saddles*. Both utilize the same steps for installation. The difference is the mounting flange.

**Note:** If bottom bar locking is provided, be sure to orient the saddles as not to interfere with the throw of the slide bolt. See **Figure 5.7**.

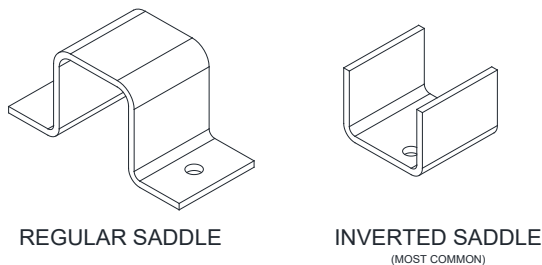

**Figure 5.6 – Tube Saddles**

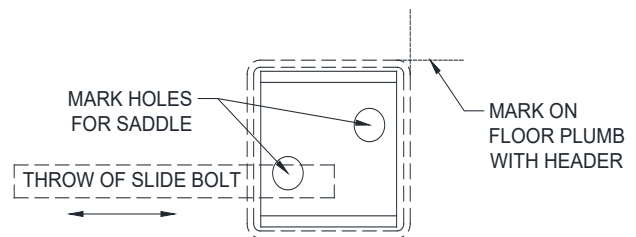

**Figure 5.7 – Tube Saddle Hole Location**

## Section 5 - Guides

5. Use the mark placed on the floor in the previous steps, to locate where the saddle will be and mark the hole locations by placing the saddle on the floor. See **Figure 5.7**.
6. Double check the width dimensions provided on the job construction drawings, then drill holes for the saddle fasteners.
7. Install saddles using the provided hardware.
8. Guides mounting to tubes, sometimes require the use of a slip joint. Locate the Slip Joint Mounting Member(s).

**Note:** *If the unit does not have slip joints and the top mounting for the tube is not provided by the manufacturer, install as recommended by supplier, then proceed to **Step 13**.*

9. Use the job information and the marks made in the previous steps to determine the correct Slip Joint Mounting Member location. Install using the provided hardware. Use only enough fasteners to hold the Mounting Members securely in place (2), as they will be removed in a later step.
10. Determine the required tube length. Refer to **Figure 5.8**.
  - a. Measure from the “Floor to Slip Joint Mounting Member” as shown in the corresponding figure below. Record this measurement.
  - b. To allow for expansion, the steel tube will need to be cut short. To determine the required “Expansion Allowance”, round the measurement taken in the previous step **up** to the nearest foot increment. Multiply the rounded value by 1/8 in/ft. Refer to the table below for examples:

|  |       |       |       |       |       |       |       |    |       |       |       |       |
|--|-------|-------|-------|-------|-------|-------|-------|----|-------|-------|-------|-------|
| Floor to slip joint mounting member (ft) | 9     | 10    | 11    | 12    | 13    | 14    | 15    | 16 | 17    | 18    | 19    | 20    |
| Expansion Allowance (in)                 | 1 1/8 | 1 1/4 | 1 3/8 | 1 1/2 | 1 5/8 | 1 3/4 | 1 7/8 | 2  | 2 1/8 | 2 1/4 | 2 3/8 | 2 1/2 |

**Table 5.1 – Slip Joint Expansion Allowances**

- c. Calculate the Tube Length:  

$$\text{Tube Length} = \text{“Floor to Slip Joint Mounting Member”} - \text{“Expansion Allowance”}$$
- d. Cut the tubes to the calculated “Tube Length”. Make sure you cut the excess tubing from the top. Otherwise you will cut off necessary mounting holes and/or notches.

**Note:** *If regular saddles are provided, the tube length will have to be adjusted because the tube will not sit on the saddle flanges instead of the floor. Subtract the thickness of the flanges from the tube length.*

11. Remove the Slip Joint Mounting Member(s). Place the Slip Joint Mounting Members in the tops of the tubes.
12. Orient the tubes (ensure the guides, mounting holes or notches are facing the correct direction.) Place the bottom of the tube over the saddle. Stand the tube upright and reattach the slip joint mounting member using the previously drilled/marked holes to locate. Use all provided fasteners at this stage. Check that installed tube is plumb.

## Section 5 - Guides

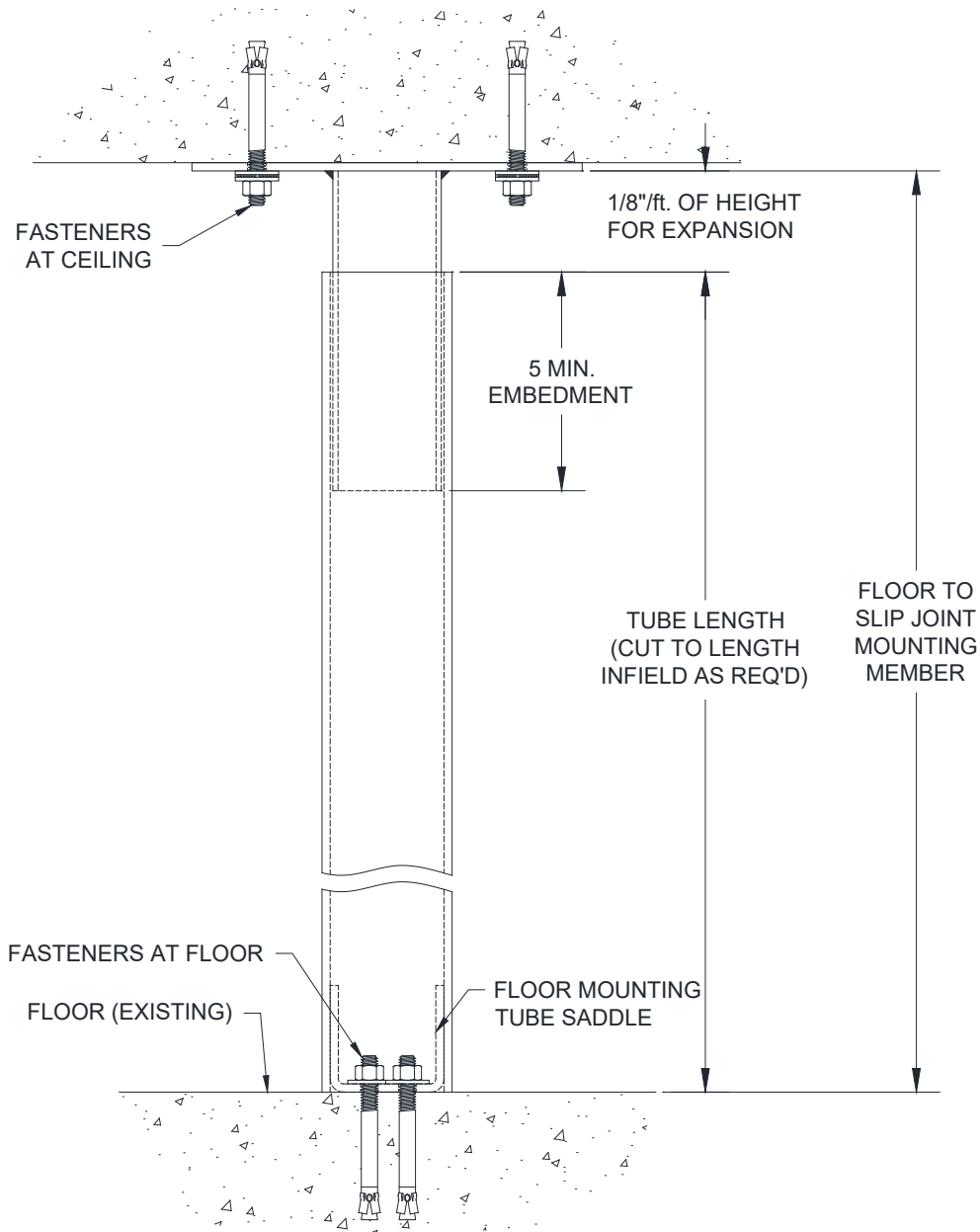

**Figure 5.8 – Slip Joint - Between Floor and Ceiling Mounting Assembly**

13. If the guide has a wall angle, as in **Figures 5.3 and 5.4**, fasten the wall angle to the mounting tube with the hardware provided. Check the job construction drawings for the required wall fastener. Tighten the wall fasteners to the recommended installation torque in the *Torque Specifications Tables* in **Section 11**.
14. At this point, the aluminum guide extrusion can be reassembled to the wall angle (or tube) using the hardware provided. It is not necessary to snap the trim into place at this time. Tighten to the recommended installation torque in the *Torque Specifications* tables in **Section 11**.

**Note:** You may find that delaying the installation of the aluminum guide extrusions until after the curtain is installed may alleviate the curtain installation process. This is a matter of preference, and will not affect the final product. If this is the case, set the guide extrusions, trim pieces and hardware aside until after the curtain is installed.

## Section 5 - Guides

- Between Jamb Units Mounting to Wall (Figures 5.9 - 5.10):

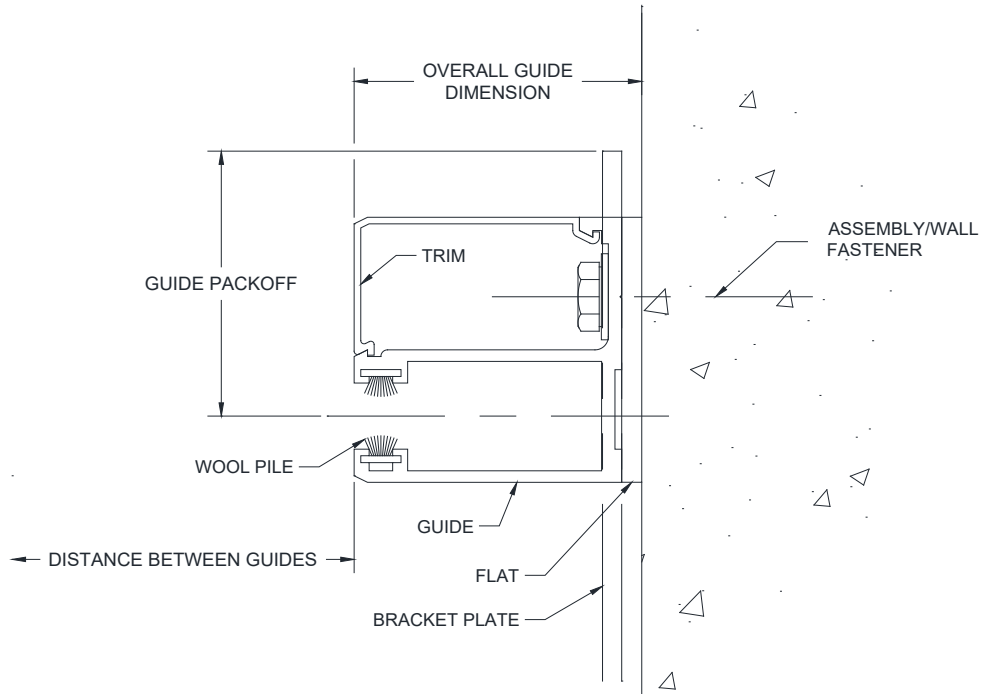

*Figure 5.9 – Between Jambs with Back-Up Flat*

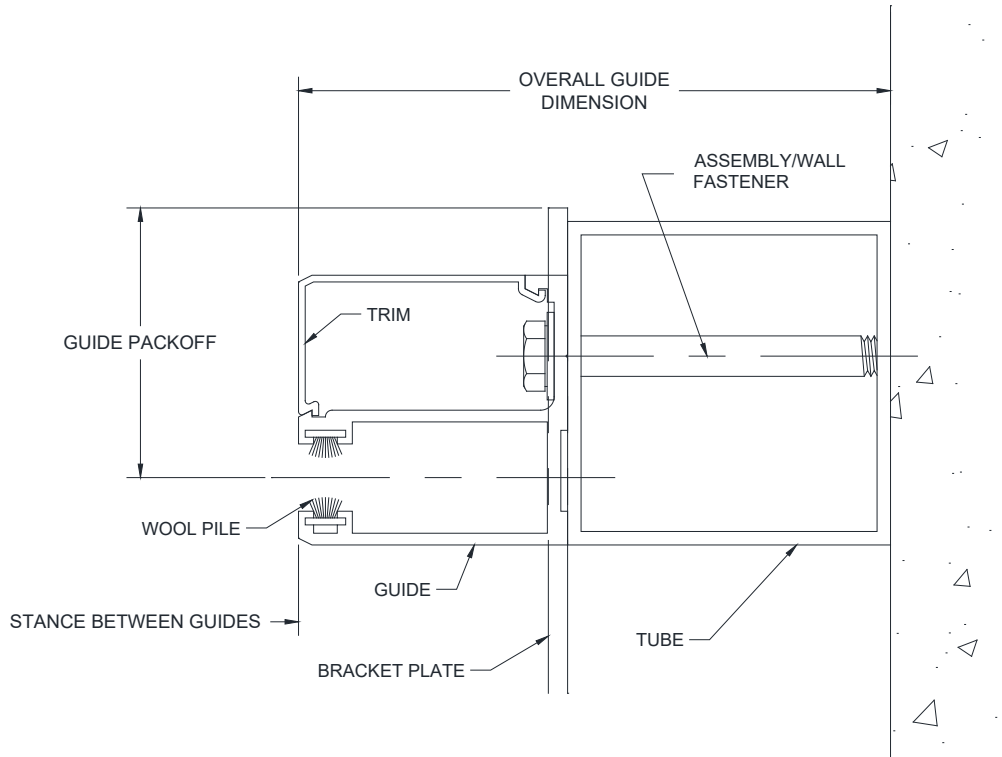

*Figure 5.10 – Between Jambs with Tube Mounting to Wall*

## Section 5 - Guides

1. Separate the trim pieces and aluminum guide extrusion from the flat or structural tubes if required.
2. Refer to the job construction drawings to determine the correct mounting location for the guide assemblies. Measure and mark the mounting locations on the floor.
3. Check the distance between these marks and compare with the job construction drawing. It will be the "Opening Width" plus the "Overall Guide Dimension" at both jambs.

### **NOTICE**

If the measurement does not equal the dimensions on the job construction drawings, **STOP**. Check the guide dimensions against those on the job construction drawings to be sure the correct guides are being installed. If so, repeat previous step and re-check.

4. Using the markings made in the previous step, position the flat/tube in the correct mounting position. Making sure the flat/tube is plumb, mark the mounting hole locations on the jamb wall using the flat /tube as a template. It may be beneficial to also score a line along the edge(s) of the flat/tube in order to realign it later.
5. Remove the flat/tube and prep the mounting holes as required.
6. Align the mounting holes in the aluminum guide extrusion and flat/tube with the prepped holes in the jamb wall.
7. Fasten the guide extrusion and flat/tube to the wall with the hardware provided. Check the job construction drawings for the required wall fastener. Tighten the wall fasteners to the recommended installation torque in the *Torque Specifications Tables* in **Section 11**. It is not necessary to snap the trim into place at this time.

**Note:** Other mounting styles offer you the choice of waiting until after the curtain is installed to install the aluminum guide extrusions. This option is not available for Between Jamb Units Mounting to Wall.

- **Mixed Guides (One Face of Wall and One Between Jambs):**

1. Refer to the job construction drawings for specific mounting information.
2. Follow the steps in the preceding sections for each of the respective guide configurations.
3. Ensure that the guide centers (centerline of the guide openings) are aligned before proceeding.

## Section 5 - Guides

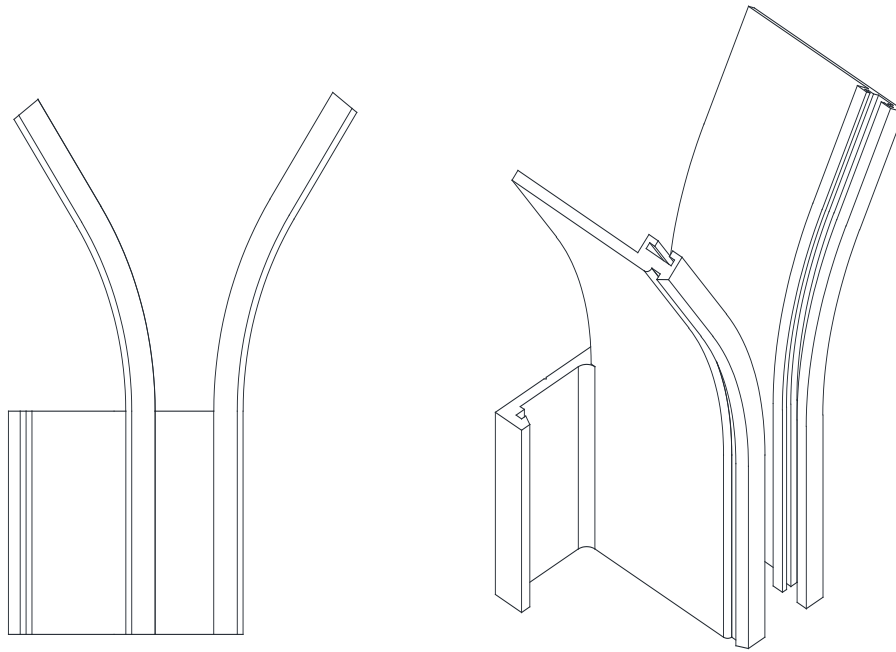

*Figure 5.11 – Flared Guides*

### **NOTICE**

Once the guides are installed it is necessary to flare the notched areas at the top outward where they project up into the coil area. This will allow the curtain assembly to enter the guides smoothly without hanging up on the top of the guides. **Note: Failure to do this may result in damage if the curtain catches on the tops of the guide during operation.**

The tops can easily be flared outward by using a crescent wrench with the jaws set open just slightly wider than the thickness of the wall of the guide assembly. Slip the wrench over the top of the guide at the center of each leg and apply even, downward pressure until the notched area flares smoothly outward. This should be done to both legs of both guide assemblies.

## Section 6 - Barrel and Brackets

### Preparation of the Barrel and Brackets

**Note:** Check to see if a hood support will be required. If so, refer to the “**Hood Support Installation**” section before proceeding to the barrel and brackets.

- Refer to the job construction drawings to determine the “coil side” of the opening, or the side of the opening on which the coil is to be installed. Then determine which jamb wall is your “operator side”, or side on which the operator is to be installed. The following instructions refer to these directional cues.

**Note:** Units **without** operators (such as push-up units) are still considered to have an “operator” side. The shaft and job drawings will be marked with “operator” side regardless of the operation of the door so that it can be used as a directional cue.

- Unpack the barrel assembly. Note the markings on the barrel, see **Figure 6.1** below.

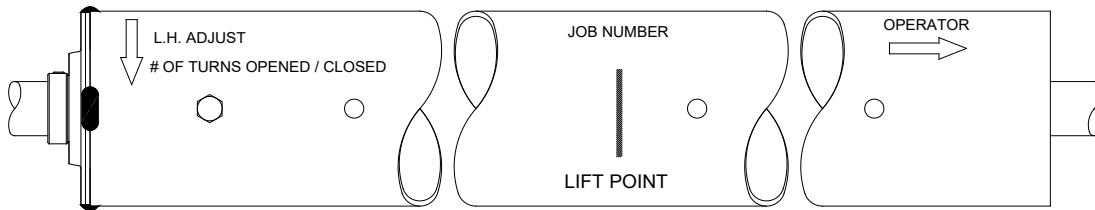
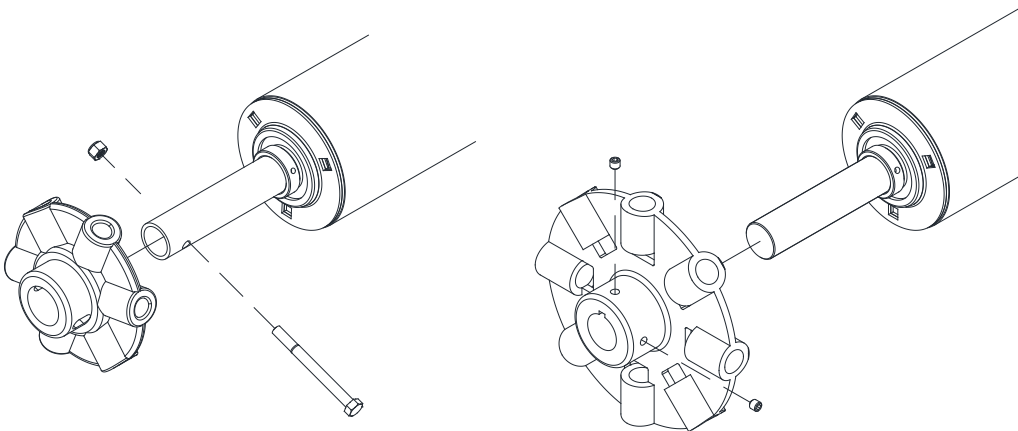

**Figure 6.1 – Barrel Markings (left hand adjust shown)**

- Position the barrel assembly on the coil side of the opening, with the end marked “operator” towards the “operator side” of the opening. In order to alleviate the ring and bracket installation, place the barrel assembly on blocks or spacers such that it is elevated off the ground.

**Note:** Choose sufficiently sized blocks. The barrel assembly should be elevated off the ground enough that the brackets can be installed without contacting the floor.

- Check to make sure the required number of turns is noted on the barrel, as shown in **Figure 6.1**. Consult the distributor or the manufacturer if you cannot locate this information. Check that these numbers match the information provided on the job information. Take note of these numbers, as access to this information may be obstructed once the curtain is installed.
- Typically the adjusting wheel is not shipped attached to the barrel. However, if the adjusting wheel is attached to the barrel, remove by loosening the bolt or set screws that secure the adjusting wheel to the barrel and sliding the wheel off the inner shaft. See **Figure 6.2**.



**Figure 6.2 – Removal of Adjustor Wheel From Barrel Assembly**

## Section 6 - Barrel and Brackets

6. Refer to the job information provided with the door to determine the correct ring type and quantity. If the unit does not require rings, skip to **Step 10**. Many larger diameter (8", 10", 12", etc.) barrel assemblies do not require rings for curtain attachment.
7. Locate the rings in the hardware bag/box provided. Check that you were supplied the correct type and quantity. (Use **Figure 6.3** as a visual aid.)
8. Use the information in **Figure 6.3** to install the rings.

**Note:** It is **critical** that the rings are installed correctly in relation to the coiling direction, or the direction of wrap as the door travel upward. The rings act as graduated spacers, meaning they increase in diameter such that the curtain wraps in a consistent and smooth manner. Use the arrows on the figures below to determine the correct orientation of the rings in relation to the coiling direction.

### SP0003 (for 4" barrels) and SP0006 (for 6" barrels) Stamped Rings, and SP0273 Cast Rings:

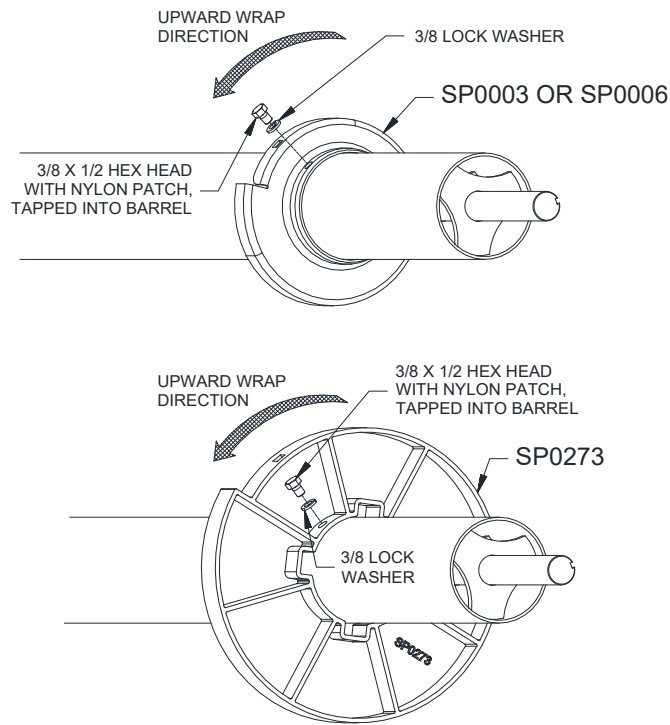

#### Installation:

- Slip the rings over the barrel, noting direction of wrap, and place over tapped hole in barrel. Insert the 3/8" x 1/2" hex bolt (with nylon patch on threads) through the ring into the tapped hole in barrel.
- Be sure rings sit straight on barrel and tighten the fasteners to minimum 20 ft lbs of torque.

### SP0251 Cast Rings:

## Section 6 - Barrel and Brackets

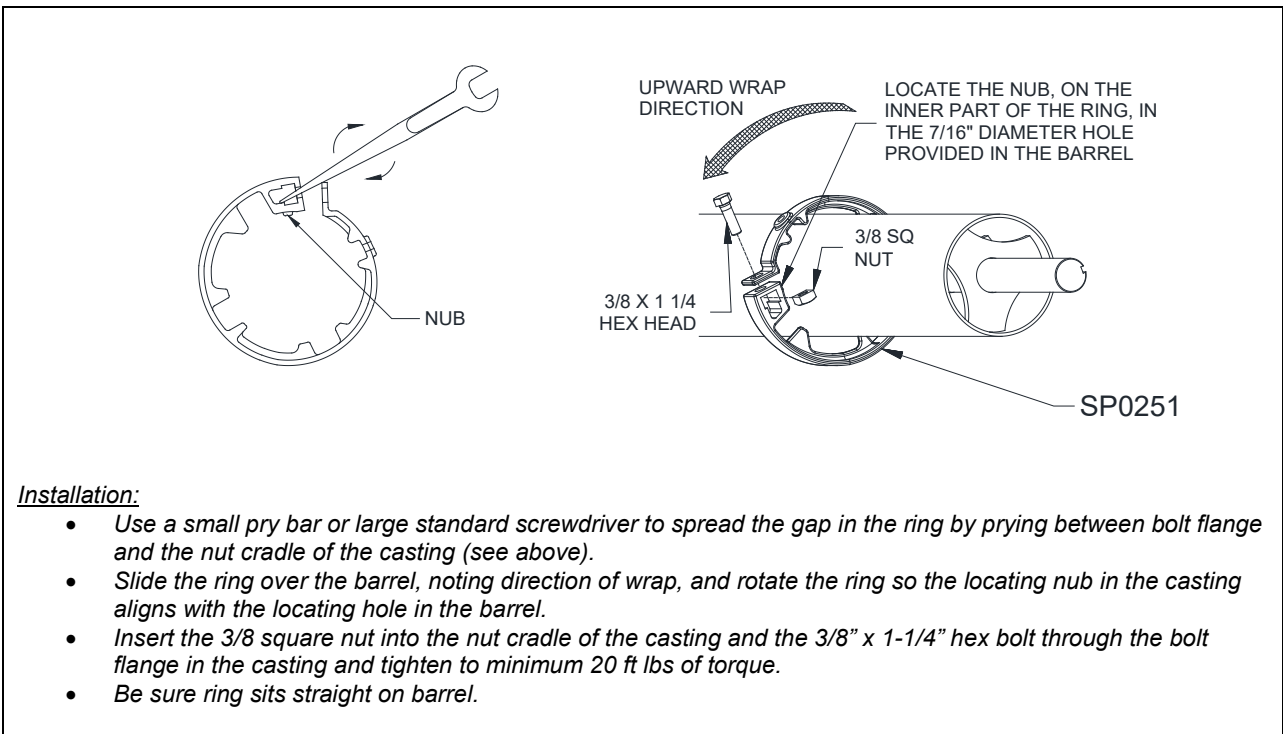

**Figure 6.3 – Ring Installation**

9. Locate the brackets. Determine the “operator” and “adjustor” brackets by referring to **Figure 6.4**. The “operator” bracket may vary significantly based on the operation of the door. The “adjustor” bracket will contain a label with spring adjustment instructions.
10. Remove the adjusting wheel if you haven’t previously, and slide the adjustor bracket over the inner shaft of the barrel assembly. Install the adjusting wheel (see **Figure 6.2**).
11. Slide the operator bracket over the gear end until the inside face of the bracket is approximately 3 inches from the edge of the outer shaft. Do not tighten the set screws at this point, as you may need to adjust the position of the bracket. You may choose to install the drive sprocket (if present) at this point.

**Note:** Do not install the operator until the barrel and bracket assembly is hoisted into position and securely fastened to the guides. Installing the operator at this stage will cause the assembly to be lopsided and cumbersome, making it difficult and potentially dangerous to hoist into position.

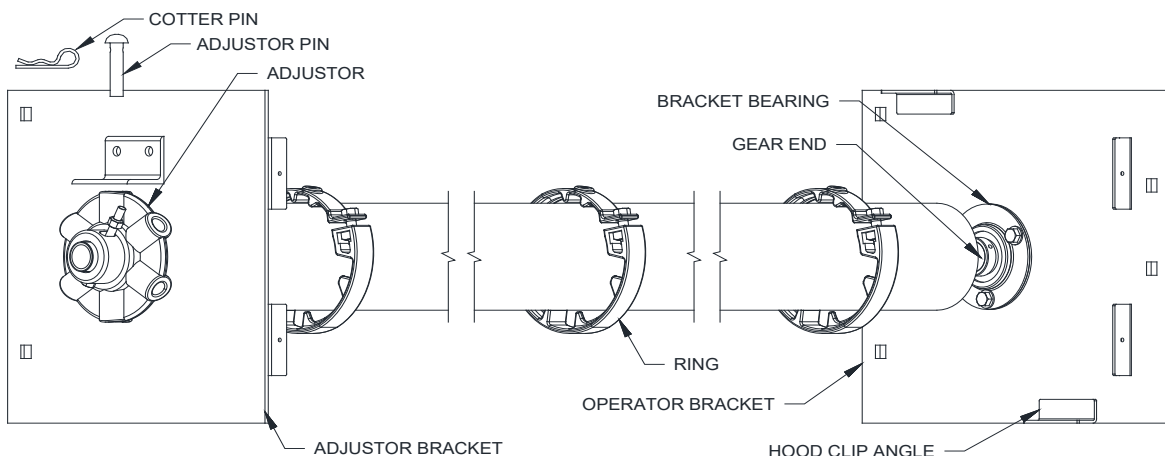

**Figure 6.4 – Brackets and Barrel Prior to Installation**

## Section 6 - Barrel and Brackets

### ▪ Hoisting and Installing Barrel Assembly

1. The following methods can be used for hoisting them into place:

- **Crane Hoisting:** Place a sling or lifting agent under the barrel assembly at the “lift point” provided on the barrel, see **Figure 6.1**.
- **Forklift Hoisting:** Space the forks evenly under the “lift point” provided on the barrel, see **Figure 6.1**. Ensure that the barrel assembly is positioned close enough to the tips of the forks that the fastening holes in the bracket can be aligned with those of the guides without the forks contacting the wall. Secure the barrel assembly to avoid the slipping off the tip of the forks.

### **⚠ WARNING**

The addition of brackets may offset the balance slightly from when the “lift point” was marked. Check to make sure the assembly is properly balanced before hoisting.

2. Before hoisting, refer to the hardware sheet and ensure that the proper type and quantity of fasteners were provided for the bracket installation. Measure the distance between the brackets and compare that to your wall angles (or between mounting angles if tubes are present). Readjust the brackets as needed before hoisting.
3. Center the barrel assembly between the guides, keeping approximately 2 feet of clearance between the barrel assembly and wall/guides.
4. Raise the barrel assembly up to the approximate bracket mounting level. The brackets should be clear of the outer and inner guide angles.

**Note:** Position the brackets in the upright position, with the mounting holes facing the wall, before moving the assembly towards the wall. It may be difficult to rotate the bracket when in close to the wall.

5. Slowly maneuver the barrel assembly towards the guide, and align the mounting holes of the brackets with those of the wall angles (or mounting angles if tubes are present).
6. Insert the specified bolts and snug tighten, see **Figure 6.5**.

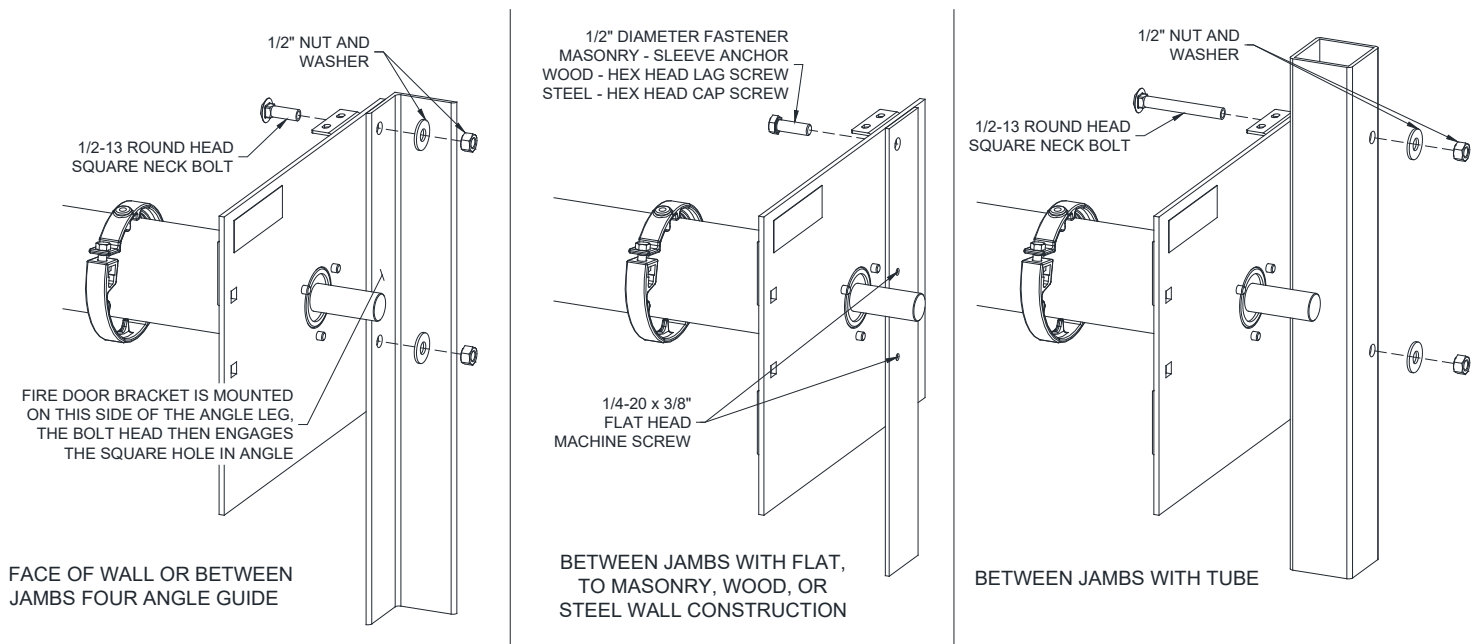

**Figure 6.5 – Bracket Mounting Configurations and Hardware**

7. Check to see that the barrel is positioned properly between the brackets. That is, so that the proper amount of space is allowed between the barrel and the brackets. Typically the space is equal at both the operator and adjustor side. Adjust as necessary.
8. Place a level in the center of the barrel. If the shaft is **not** level:
  - Check the dimensions of the brackets from the top of the bracket to the center of the barrel.
  - Verify that the bracket mounting fasteners are the same distance from the top of the bracket.
    - a. If the dimensions **are not** correct, contact the Service Department.

## Section 6 - Barrel and Brackets

- b. If the dimensions **are** correct, the floor may be out of level, causing the bracket mounting holes in the guides to be out of alignment.
9. Fully tighten mounting bolts to the torque specifications in this manual. See *Torque Specification Tables* in **Section 11**.

### **NOTICE**

Proper pretension of the bracket mounting bolts will benefit the life of the bolts and brackets.

10. If the adjusting wheel was not previously installed, install it now. Do not install the adjustor pin yet.

## Section 7 - Motor Operator Installation

### Motor Operator Installation (if required):

1. Unpack the motor operator from the shipping box and retrieve the *Operator Mounting Bracket* and bolts provided in the kit.
2. There are several motor mounting configurations that can be formed with the supplied components. Refer to the shop drawings and components supplied with the kit in order to identify the specific style of mounting ordered for the unit. Some of the types of mounting are:
  - Vertical Bracket
  - Vertical Bracket Mounting With Tight Headroom
  - Wall Mounting
  - Horizontal Top of Coil
  - Horizontal Front of Coil
  - Horizontal Upside Down Front of Coil
  - Vertical Tube Mounting
  - Vertical Tube Top of Coil
3. If an operator cover is supplied, refer to the included Operator Cover Installation Instructions to assemble the cover mounting plate with the operator mounting bracket.
4. Mount the operator mounting bracket to the operator using the supplied fasteners.
5. Mount the operator-mounting bracket to the operator bracket according to the shop drawings using the supplied fasteners.
6. Install controls and wire the operator. Refer to the wiring diagram provided with the operator for proper connections and voltages. The controls should be installed in an area from which the door/opening is clearly visible. This will allow an individual operating the unit to make a visual inspection of the opening for any obstacles or other potential hazards before setting the door into motion.

**Note:** Do not attempt to set the upper and lower limits until the curtain is installed.

### Attaching Additional Bracing (if required):

1. Attach a clip angle to the operator mounting bracket and the bracing angle to the clip angle. Snug all bolts.
2. Mount the other supplied clip angle to the bracing angle and swing the bracing angle to the wall or structural support.
3. Align the mounting face of the clip angle with the face of the wall, mark and drill a mounting hole for the size of the supplied mounting fastener, and secure the clip angle to the wall with the fastener.
4. Square the operator-mounting bracket, adjusting the bracing angle as necessary, and fully tighten all the mounting bolts.
5. Lift the motor operator into position on the mounting bracket and align it with the appropriate hole pattern. **See figure for operator mounting details.**
6. Insert the fasteners included in the kit from the bracket side first into the mounting foot of the operator and tighten the nuts with lock washers.

**Note:** All mounting bolts are supplied with nuts and lock washers.

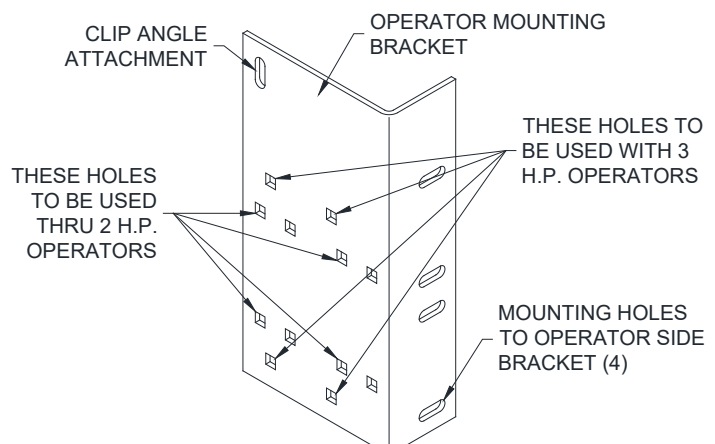
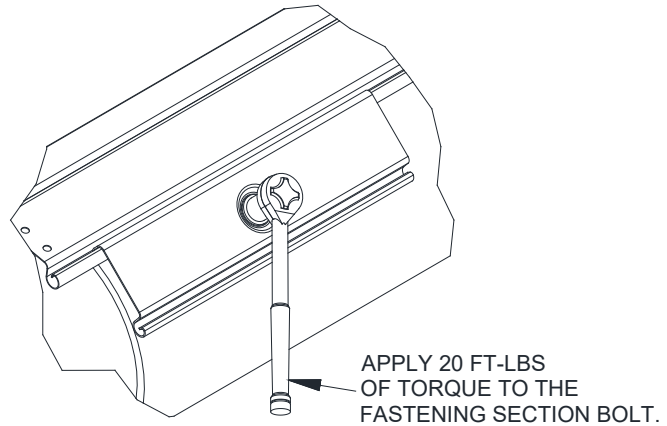

**Figure 7.1 - Additional Operator Bracing**

## Section 8 – Curtain Installation

### ▪ Curtain Installation

1. The guides are usually shipped with the stoppers positioned so they will not interfere with the bottom bar to alleviate the installation process. Check to make sure the stoppers are positioned correctly for installation (whether they are installed at this point or not.)
2. Open the curtain packaging. Leave the plastic straps that keep the curtain from uncoiling in place. It may also be beneficial to leave some of the packaging under the curtain to protect the finish during installation.
3. The coil will be provided with the top of the curtain on the outside, thus leaving the fastening sections exposed. Position the coil on the floor between the guides so that the open end of the fastening sections is facing up and nearer the wall.
4. Locate the curtain attachment hardware provided with the unit. Refer to the job information to ensure you have the correct type and quantity.
5. Lift the coil until it is just below the shaft. Using appropriately rated straps, sling the coil from the shaft as shown in **Figure 8.3**. Remove the plastic strapping securing the coil at this point.

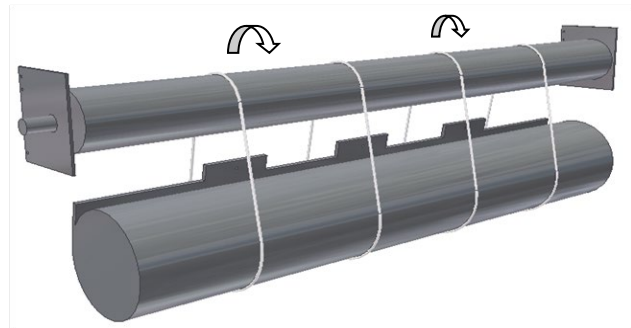

**Figure 8.1 - Installing the Fastening Section**

6. Uncoil the curtain enough for the fastening sections to reach the attachment points on the shaft. Fasten them by aligning the fastening section with the hole in the ring or shaft respectively, and fasten using the provided hardware (See **Figure 8.1**). If the curtain is too heavy to uncoil by hand, use the method described in the following step to get the fastening sections in position.
7. Uncoiling a slung curtain using the operator/adjusting wheel:
  - For units with operators, use the hand chain, crank or override feature of the motor to rotate the shaft in the “open” direction. Be sure not to overrun the limits of the motor. The upper motor limit may have to be adjusted to reel the entire curtain onto the shaft. Make sure the adjusting wheel is **not** pinned in place for this operation and that the shaft spins freely, so as to **not** backwind the springs.
  - For push-up units, turns can be added to the adjusting wheel in order to assist in rotating the shaft. Keeping count of the turns added to the spring at this stage will save installation time later.
8. Continue to rotate the shaft, reeling the curtain out of the sling and onto the shaft until the bottom bar reaches the bottom of the bracket.

**Note:** If you have not already installed the aluminum guide extrusions, install them now.

9. Feed the bottom bar into the guides and lower the curtain until the bottom bar is below the stopper location.
10. Since there is no spring tension holding the curtain open, the curtain may fall if released. If the operator cannot be used to hold the curtain in the open position, place C-clamps or vice grips on the guides just below the bottom bar -or- rest the bottom bar on the slings used to hang the shaft in the previous steps to hold the door open
11. Reposition the stoppers so that they protrude into the opening.



**Figure 8.3 - Installing the Curtain**

## Section 8 – Curtain Installation

### ▪ Applying Spring Turns (not including chain sprocket adjusters):

1. Refer to the job information or markings on the shaft for the number of spring turns required on the unit.
2. To apply spring charge, remove cotter and stop pin from adjusting wheel.

**Note:** SA0005 adjustors require the use of an adjustor bar as a stop as well as a 3/8" thick x 2" wide x 30" to 40" long A36 steel bars to apply spring torque. See **Figure 8.3**.

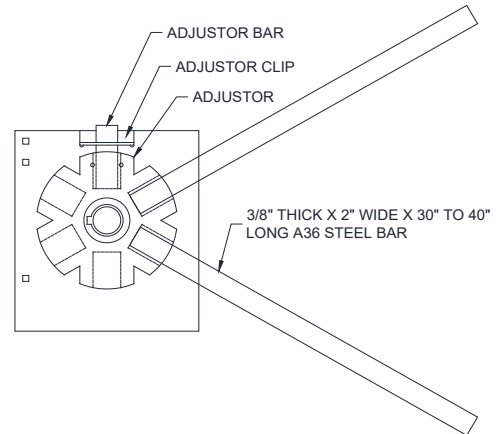

**Figure 8.4 – SA0005 Spring Adjustor**

3. Using two 1/2" diameter (or greater depending on the adjusting wheel) steel rods, approximately 18"-24" long, apply spring torque by inserting both rods into adjustor wheel one above the other.
4. Rotate wheel in a direction of raising the curtain. Maintain applied torque with upper rod, while removing lower rod. RE-insert this rod above the other and continue applying torque one notch at a time using this hand over hand procedure until the specified number of spring turns has been applied.
5. Replace stop pin or bar into adjustor wheel as shown in **Figure 8.5** and insert the cotter pin to hold it in place.
6. The spring should now hold the door in the open position. Remove any devices applied to hold the door in the open position (clamps, slings, vice grip, etc.)
7. Check curtain for ease of operation. If the door operates correctly, skip to the next section, if not, continue to the next step.
8. Final spring tension adjustment, if necessary, should be increased or decreased with the curtain in the fully open position. Insert one [two if necessary] 1/2" diameter steel rods into adjustor wheel.
9. Remove cotter pin and stop pin from adjustor wheel and begin to increase or decrease tension.
  - To increase tension, rotate the wheel in the direction of raising the curtain.
  - To decrease tension, carefully rotate the wheel in the direction of lowering the curtain.
10. Recheck the balance in 1/8 rotation increments (one notch at a time). Re-insert stop pin and cotter pin.

**Note:** If you have difficulty balancing the door, or the number of turns required to balance the door varies significantly from the quantity provided, contact the **Service Department**.

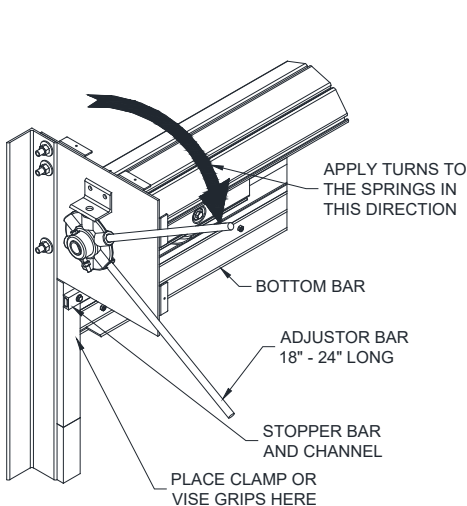

**Figure 8.5 – Clamping the Guides, Applying Turns.**

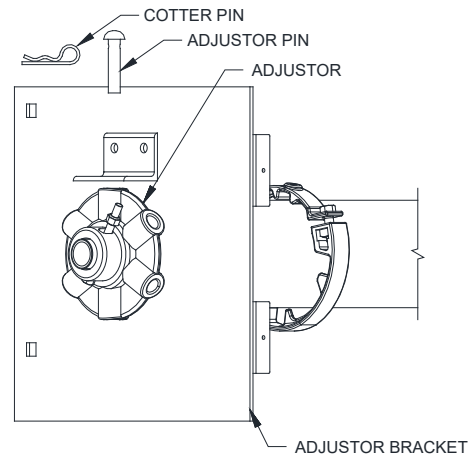

**Figure 8.6 – Pinning the Adjusting Wheel**

## Section 9 – Hood Support Installation

▪ **Hood Support installation:**

1. Refer to the job information to determine the type and quantity of hood supports required for your door. Hood supports will be noted on the elevation view of the job construction drawings. See **Figure 9.1** for hood support types.

**Figure 9.1 - Hood Supports**

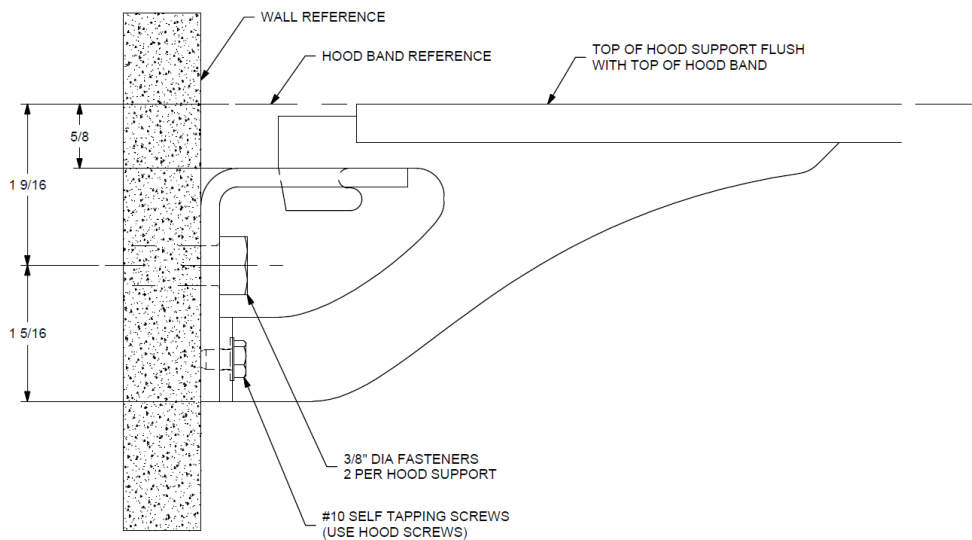
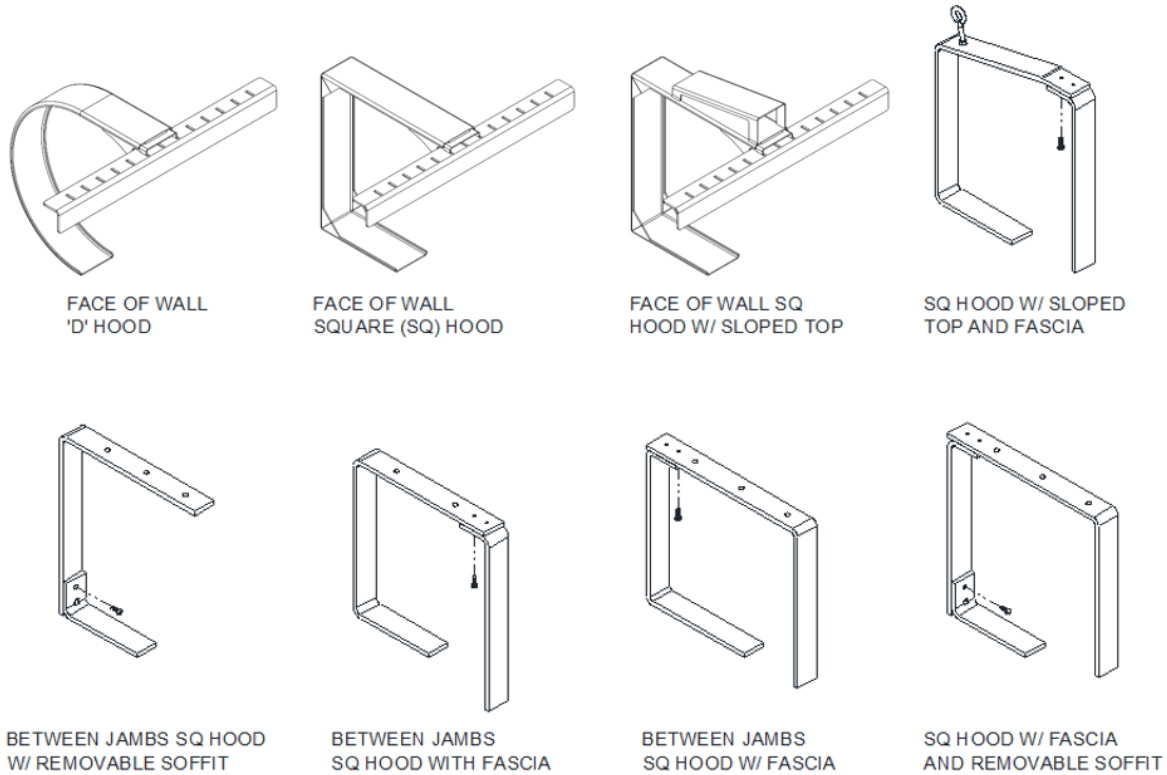

**Note:** See above detail for face of wall units; the wall angle is offset 5/8" from top of hood band to allow hood support to be flush while installing the hood.

## Section 9 – Hood Support Installation

2. Determine where the support(s) will be located between the guides.
  - a. If multiple supports are required, see the job construction drawings to determine the centerline of each.
  - b. If a single support is required, it will be located at the center of the unit.
3. Mark a line on the lintel at the centerline of each support.
4. Check the construction at the support locations to be sure it is strong enough to handle the weight of the hood.

**Note:** If the construction is not strong enough, do not proceed until rectified.

5. The term "top of coil" refers to the top edges of the brackets or hood band, see **Figure 9.2**
  - a. If there is a ceiling at the top of the coil, skip the next step.

**Figure 9.2 – Top of Coil**

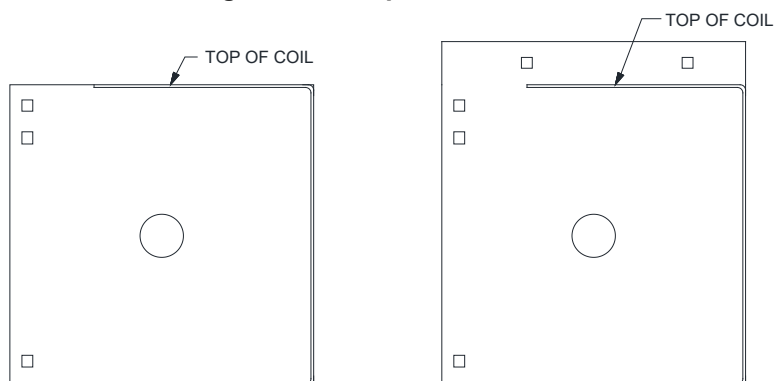

6. Mark a line at the top of the coil at both guides of the unit. Project the lines together to make a continuous line.
  - a. This will help locate the top of the hood support which will keep the hood level.
7. Project a line from the fascia mounting location (fascia mounting channel or fascia side of the tube) from one guide to the other.
8. Mark a line at the support centerline along the fascia line.
9. Prepare the location of the attachment point of the support(s) prior to installing the barrel. This will make installing the support much easier when the time comes to attach it to the lintel/header or ceiling.
  - a. Hold the support in place at the determined location and mark the mounting hole locations.
  - b. Drill holes in the construction and hood support mounting angle.
10. Attach the hood support mounting angle to the lintel/header or ceiling to be sure the mounting holes were located properly.
11. Once the barrel, brackets, curtain are installed, and necessary testing was done on the unit, re-install the hood support.

## Section 10 - Hood, Fascia, and Covers

### ▪ **Hood and Fascia installation:**

1. Determine what type of hood is provided. See **Figure 10.1** for possible hood configurations. This can be done by:
  - Looking at the brackets and identifying a half-circle shaped flat (D-shaped hood) or straight flats (square or sloped).
  - Looking in the hood box and comparing to the job construction drawings.

**Figure 10.1 – Hood Configurations**

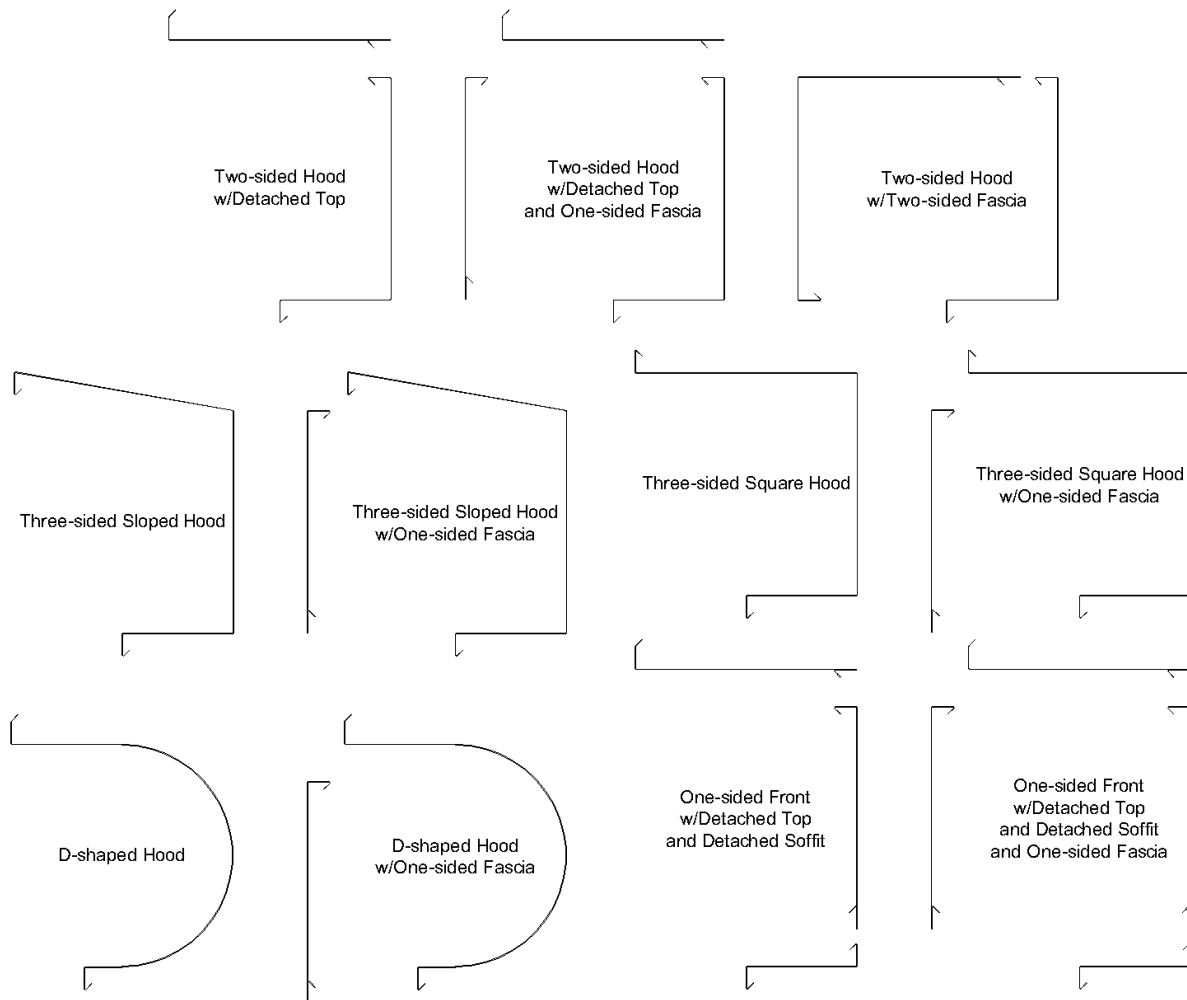

2. If no fascia is included, skip to Step 3.

If a fascia is included, it will be installed first. Fascia fastening varies by job condition but is typically secured to the guides, the brackets, or to the wall. Install the right-most section first, ending in “-R”. Continue leftward adding fascia sections, overlapping the right-hand section by 4”

3. If the hood has more than one section (separate left, right, or center), skip to Step 5.

For single-section hoods, begin with the front-most piece. Install by holding the hood up to the coil area and pushing it against the flats on the brackets. Center the hood so the gap is the same at both brackets. Pre-drill with a #21 or 5/32” drill in at least one place on every face of the hood, at both the left and right sides. See **Figure 10.3** for recommended fastener locations.

## Section 10 - Hood, Fascia, and Covers

4. After fastening the first hood piece, continue with the detached soffit and top, if included.
5. For hoods with multiple sections, begin with the front-most right-hand hood piece, ending in “-R”.

Install by holding the hood up to the coil area and pushing it against the flats on the brackets. Butt the hood piece against the bracket to minimize the gap. Pre-drill with a #21 or 5/32” drill in at least one place on every face of the hood, at both the left and right sides. See Figure 10.3 for recommended fastener locations.

The hood section should cover the hood support completely (approx. 4”). Temporarily clamp hood section to hood support until the next section is installed.

6. Continue leftward installing sections of the same type of hood piece before starting with the right-most soffit or top pieces. See **Figure 10.2** for an example of the order hood pieces should be installed. No cover is used on the splice between hood sections.

**Figure 10.2 – Multiple Hood Sections**

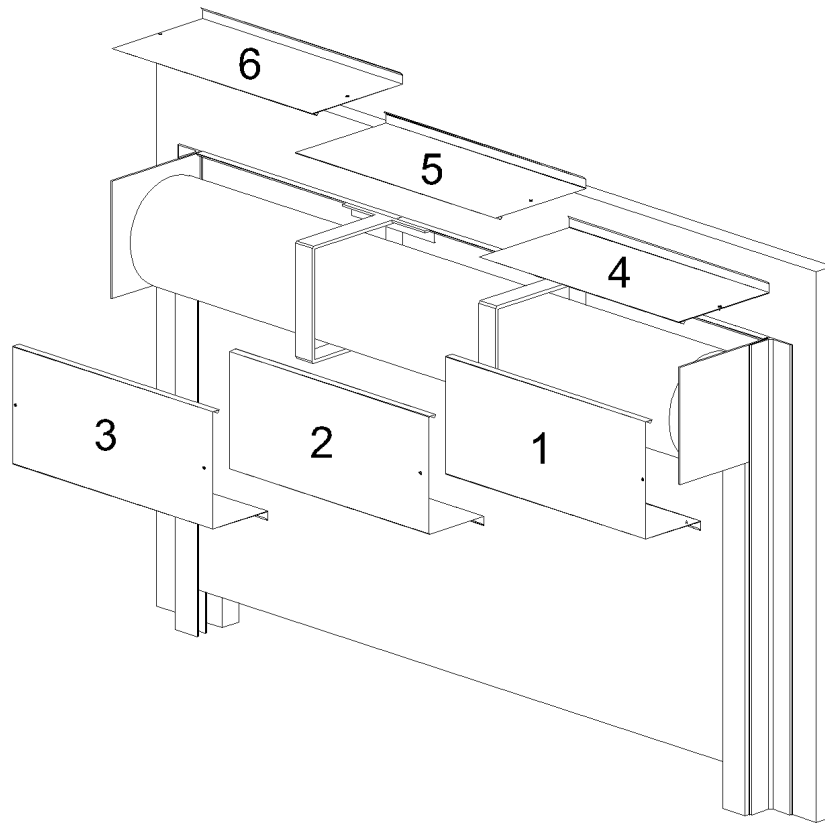

## Section 10 - Hood, Fascia, and Covers

Figure 10.3 – Recommended Fastener Locations

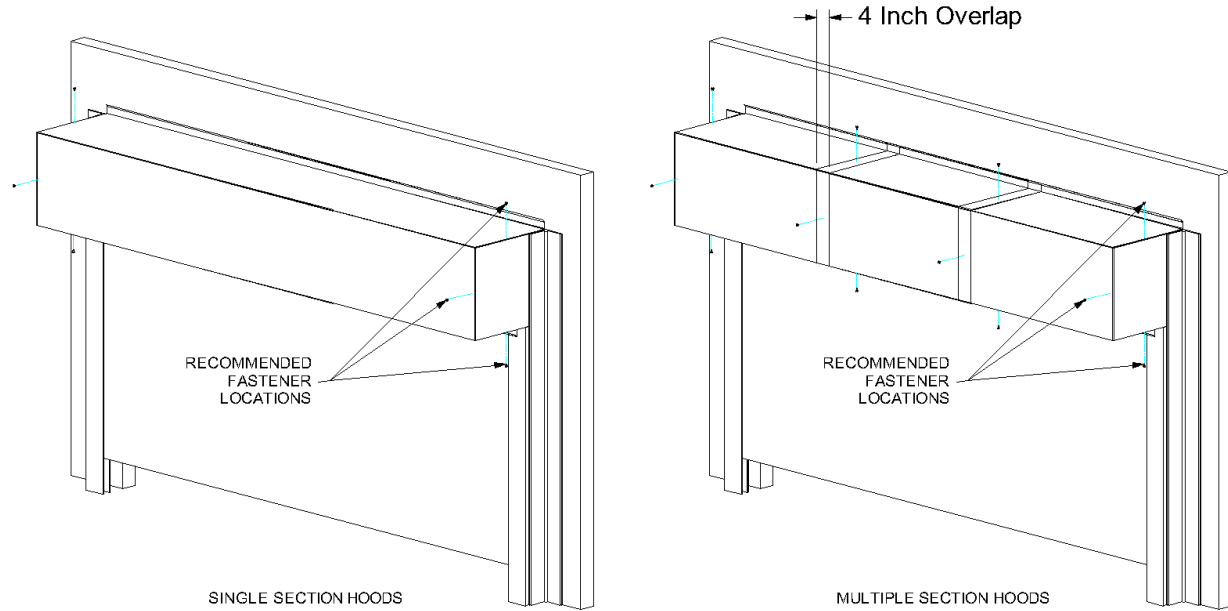

7. If the door is mounted in a weathered or exterior location, caulk the part of the hood that contacts the wall.

▪ **Cover installation:**

1. Once the unit is installed and operating correctly, the covers can be installed.
2. Hood screws may have to be removed and reinstalled to install covers properly.
3. If the cover mounts to the side of the door bracket, pre-drill holes in the bracket to ease installation. A #21 drill size is recommended.
4. If an operator or adjustor cover is provided, individual installation instructions are provided with each cover along with the necessary hardware to attach the cover.
5. Once the cover is installed, operate the door a few more times to be sure there is no interference between the moving components inside the cover and the cover itself.
6. If the door is mounted on the exterior of the building, a bead of silicone sealant should be applied around the entire perimeter of the cover, as it will provide additional protection to the door components.

## Section 11 - Torque Specifications

*Table 11.1 - Torque Recommendations for Guide Assembly and Wall Fasteners*

| Bolt size/type  | Torque (ft lbs) <sup>a</sup> |
|---|------------------------------|
| 1/4-20 Grade 2 steel bolt   | 6                            |
| 5/16-18 Black Oxide Socket Cap  | 25                           |
| 3/8-16 18-8 stainless steel bolt  | 20                           |
| 3/8-16 Grade 2 steel bolt   | 20                           |
| 3/8-16 Grade 5 steel bolt   | 31                           |
| 1/2-13 Grade 5 steel bolt   | 75                           |
| 1/2-13 Grade 8 steel bolt   | 107                          |
| 5/8-11 Grade 8 steel bolt   | 212                          |
| 3/4-10 Grade 8 steel bolt   | 376                          |
| <sup>a</sup> The recommended torque for steel bolts is based on a plated bolt that has not been lubricated. |                              |

*Table 11.2 - Torque Recommendations for Solid Masonry Wall Anchors*

| Anchor Size<br>(nominal)   | Manufacturer/Torque (ft lbs) <sup>a</sup> |                   |
|--|---|-------------------|
|  | Simpson Wedge-All                         | Hilti-Kwik Bolt 3 |
| 3/8  | 30  | 20                |
| 1/2  | 60  | 40                |
| 5/8  | 90  | 85                |
| 3/4  | 150                                       | 150               |
| <sup>a</sup> Torque values for grout filled block are different, reference bolt manufacturer for these values. |   |                   |

## Section 12 - Maintenance Schedule

▪ **Maintenance Schedule:**

**Note:** If any of the following problems exist, **do not** operate the door until repaired.

| Component            | What to look for and how often the components must be inspected:   | Weekly | Monthly | Quarterly | What to do if problem exists:  |
|----------------------|--|--------|---------|-----------|--|
| Curtain & Bottom Bar | Are any curtain components damaged (slats, endlocks, etc.)?  | X      |         |           | Contact Service about replacing damaged parts.   |
|                      | Is bottom bar damaged?   | X      |         |           | Contact Service about replacing damaged parts.   |
|                      | Are bottom bar fasteners in place and properly tightened?  |        | X       |           | Fasteners must be inspected/replaced and properly tightened.   |
|                      | Are fasteners attaching curtain to the barrel in place and properly tightened?   |        | X       |           | Fasteners must be inspected/replaced and properly tightened.   |
|                      | Do you notice any hang-ups, jamming or other problems preventing the door from moving smoothly throughout the opening? | X      |         |           | Check for external issues, if none exist, contact Service.   |
|                      | Do you notice any odd or excessive noise when the door is operated?  | X      |         |           | Check for external issues, if none exist, contact Service.   |
|                      | If there is a bottom seal, is it damaged?  |        | X       |           | Contact Service about replacing damaged parts.   |
|                      | If there is locking, does it function properly?  | X      |         |           | Check for external issues, if none exist, contact Service.   |
| Brackets             | Are brackets plumb and perpendicular with wall?  |        |         | X         | Contact Service.   |
|                      | Are bracket fasteners in place and properly tightened?   |        |         | X         | Fasteners must be inspected/replaced and properly tightened.   |
|                      | Do you notice signs of excessive wear on the bearings (i.e. binding, excessive noise, etc.)?                           |        | X       |           | If there is a grease fitting, apply grease, if not, contact Service.   |
|                      | Is adjusting wheel & pin secure?   |        |         | X         | Contact Service.   |
|                      | Is drive chain sufficiently lubricated?  |        |         | X         | Apply chain lube.  |
|                      | Is drive chain in need of tightening?  |        |         | X         | Contact Service for instructions on how to tension the chain.  |
|                      | Is drive or driven sprocket damaged?   |        | X       |           | Contact Service about replacing damaged parts.   |
| Guides               | Are wall fasteners in place and properly tightened?  |        | X       |           | Fasteners must be inspected/replaced and properly tightened.   |
|                      | Are guide assembly fasteners in place and properly tightened?  |        | X       |           | Fasteners must be inspected/replaced and properly tightened.   |
|                      | Is guide gap dimension correct?  |        | X       |           | Check job construction drawings and adjust gap as required. If job construction drawings are not available, contact Service. |
|                      | Are any of the guide parts bent or damaged?  |        | X       |           | Contact Service.   |
|                      | Are stoppers loose, damaged, or missing?   |        | X       |           | Stoppers must be inspected/replaced and properly tightened.  |
| Hood and Fascia      | Is hood/fascia dented or damaged?  |        |         | X         | Remove hood/fascia. Repair if possible. If not leave hood/fascia off and contact Service.                                    |
|                      | Is curtain rubbing against the hood/fascia?  | X      |         |           | Hood/fascia may have been damaged. Contact Service.  |
|                      | Is hood/fascia level?  |        |         | X         | Check fasteners, they may be loose or missing. Replace as soon as possible.  |
|                      | Are guide assembly fasteners in place and properly tightened?  |        | X       |           | Fasteners must be inspected/replaced and properly tightened.   |
|                      | Is hood support level?   |        |         | X         | Check fasteners, they may be loose or missing. Replace as soon as possible.  |

## Section 12 - Maintenance Schedule

|                |   |   |   |   |  |
|----------------|---|---|---|---|--|
| Door operation | Does the door require excessive force to open?  |   | X |   | Check for hang-ups or obstructions. Ensure spring tension is set correctly. Contact Service.                   |
|                | If the door contains locking, does the locking mechanism function properly and securely hold the door in the closed position?                             |   | X |   | Check for damage and other external issues. Contact Service.   |
|                | If there is a sensing edge, does it function properly?  | X |   |   | Cut power and check for loose wires. Contact Service for further instruction.                                  |
| Motor Operator | Are the fasteners attaching the motor-to-the mounting bracket, and mounting bracket-to-the door bracket secure?   |   |   | X | Fasteners must be inspected/replaced and properly tightened. Contact Service for replacement hardware.         |
|                | Are the sprockets properly aligned?   |   |   | X | Realign the sprockets as secure using the set screws. Recheck chain tension.                                   |
|                | Are the sprocket keys properly aligned with sprockets and securely fastened with the set screws?  |   |   | X | Reposition the keys so they fully engage the keyway in the sprocket. Tighten the set screws.                   |
|                | Is the door stopping correctly at the open (before bottom bar contacts the stoppers) and closed (as soon as the bottom bar contacts the floor) positions? |   | X |   | Limits may have to be adjusted in the motor operator. Refer to the operator owner's manual or contact Service. |
|                | Is the operator functioning normally?   |   | X |   | Refer to the <i>Operator Troubleshooting Table</i> on the following page to diagnose the problem.              |

## Section 12 - Maintenance Schedule

▪ **Operator Troubleshooting:**

**Note:** If you suspect you are having an issue with your operator, use the following table to determine the potential causes. If the provided solution does not eliminate the issue, or the table does not address your particular problem, contact the Service Department.

| Component                      | Problem   | Potential Cause  | Solution  |
|--------------------------------|---|--|---|
| Motor Operator                 | Motor Operator does not run when OPEN or CLOSE button is pushed         | The circuit breaker may be flipped or fuse blown.                                | Reset breaker or replace fuse. Contact Service if replacement fuse is needed.   |
|                                |   | The thermal overload may be tripped.   | Reset thermal overload.   |
|                                |   | Manual interlock switch is open (on units with emergency operator).              | Close manual interlocks.  |
|                                |   | External interlock may be opened.  | Close external interlock.   |
|                                | Motor operator runs but the door does not move                          | Sprocket key may be missing or drive chain may be broken.                        | Contact Service for repair parts. Install key or replace chain.   |
|                                |   | Clutch may be slipping.  | Adjust if possible. Contact Service otherwise.  |
|                                | Motor hums but does not run   | Door or drive chain may be jamming.  | Check for hang-ups or obstructions. Try to operate manually. If issue persists, contact Service.                          |
|                                |   | Dead phase in 3 phase system.  | Check power supply.   |
|                                |   | Brake does not release.  | Check power to brake solenoid.  |
|                                |   | Open motor winding.  | Check that all connections are secure.  |
|                                | Motor operator runs in wrong direction and limits do not function       | 3 phase operator power supply is out of phase.                                   | Interchange any 2 power leads to unit.  |
|                                | Door drifts when motor shuts off  | Brake may be improperly adjusted or broken.                                      | Check brake components. Contact Service for replacement parts or adjust instructions.                                     |
|                                | Motor operator does not shut off at full OPEN or at full CLOSE position | Limits may need adjustment.  | Refer to the operator owner's manual to readjust limits.  |
|                                |   | Sprocket on limit shaft may be slipping or limit drive chain may be broken.      | Ensure sprocket key is correctly installed and set screws are tightened. Contact Service for replacement chain if broken. |
| Limit switch may be defective. |   | Contact Service.   |   |
| Limit Switches                 | Limit switch does not hold setting                                      | Drive chain may be too loose, allowing the chain to jump sprocket teeth.         | Adjust chain to proper tension. Contact Service for additional information.   |
|                                |   | Limit nut retainer not engaging slots in limit nuts.                             | Be sure retainer is securely engaged in slots of both limit nuts.   |
|                                |   | Limit nuts binding on screw threads, allowing them to jump position on retainer. | Lube screw thread. Check that limit nuts turn freely.   |

## Appendix A - Chain Sprocket Adjustor

### Chain Sprocket Adjustor:

1. Loosen the shaft collar set screws. Remove the shaft collar and support strap from the adjusting wheel stud.
2. Place the bracket plate onto the inner shaft.
3. After the shaft sprocket is on the inner shaft, remove the 3/4"-10 x 1-1/2" bolts.
4. Install the square key into the shaft sprocket and inner shaft key seat.
5. Align the shaft sprocket with the sprocket on the adjusting wheel.
6. Tighten the set screws on the shaft sprocket to secure it to the inner shaft.
7. Place the support strap onto the adjusting wheel stud and over the inner shaft. Be sure that the washers are between the support strap and the adjusting wheel.
8. Replace the shaft collar on the adjusting wheel stud and tighten the set screws. When replacing shaft collar, allow clearance (.030") so that the adjusting wheel can rotate freely.

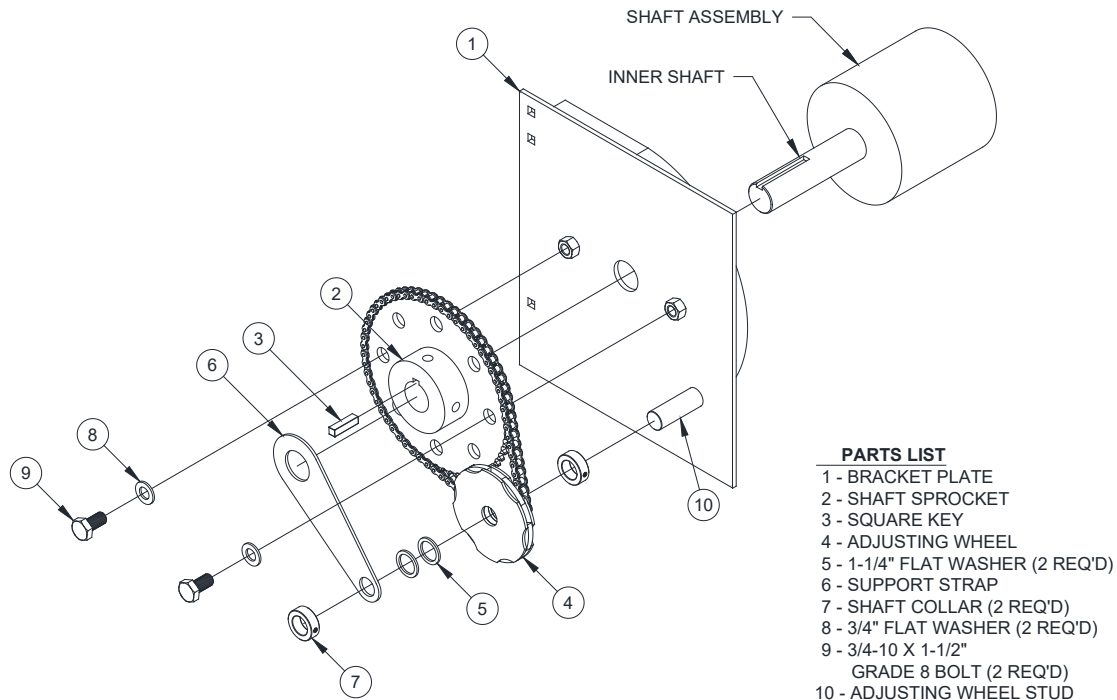

*Figure 13.1 – Chain Sprocket Adjustor Assembly*

### **WARNING**

Apply tension with door in the fully open position only. Do not operate door from the fully open position without first installing both 3/4"-10 x 1-1/2" grade 8 bolts. Roller chain is not intended to hold extreme loads and could break causing property damage and serious injury or death.

9. To apply spring turns, be sure the 3/4-10 x 1-1/2" grade 8 bolts are removed from the shaft sprocket.
10. Use a 1-1/8" high x 3/8" thick x 40" long ASTM A36 minimum bar to apply spring torque. See the job construction drawing (elevation view) for the number of initial spring turns to apply to the small adjusting wheel and the direction of rotation.
11. After the correct quantity of spring turns has been applied, use the 3/4"-10 x 1-1/2" Grade 8 bolts to fasten the shaft sprocket to the bracket plate. Torque bolts to 365 - 375 ft-lbs.

## Appendix B - Tube Motors

### ▪ Tube Motor Installation

#### 1. Install operator bracket:

##### a. Type 5 & 6 Tube Motors:

Position the angle bracket kit onto the outside face on the operator bracket as shown in **Figure 12.1**. Fasten using the (4) 1/4-20 x 3/4 button head screws, and nuts.



*Figure 12.1 – Angle Bracket Kit, Type 5 DMI and 6 DMI*

**Note:** The metric sized flat head screws, nuts & external tooth lock washer provided with the angle bracket kit will not be used.

Slide the operator bracket over motor head. Position bracket so that crank shaft is vertical & opposite the wall side. Align the (4) holes in the angle bracket kit with the corresponding holes in the tube motor and fasten using the provided hardware. See **Figure 12.2**.

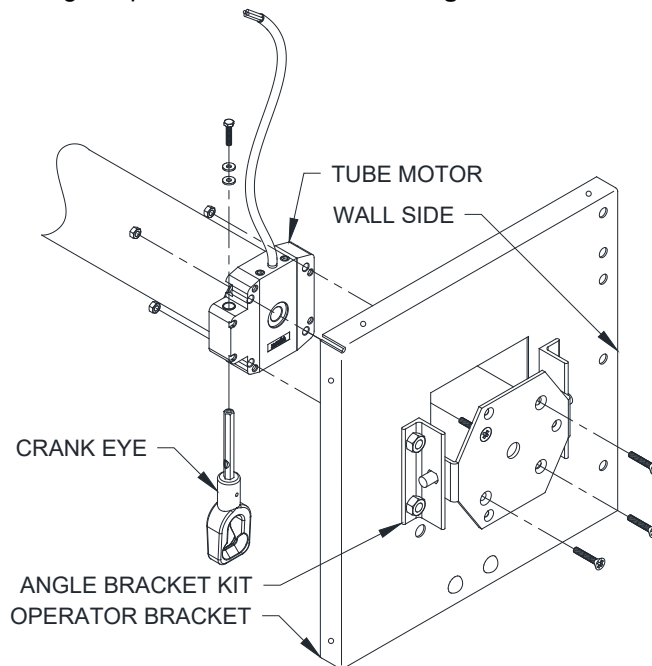

*Figure 12.2 – 3" Shaft Assembly*

##### b. Type 8 Tube Motors:

Reference motor instructions if LH operating is required. Attach lower mounting angle to bracket using provided hardware. Slide operator bracket over motor head, position the lower mounting stud into the lower mounting angle, making sure that the bushing is positioned between the motor and the angle. Install the upper mounting angle and bushing. See **Figure 12.3**.

## Appendix B - Tube Motors

**Note:** At this time, make sure that all rings (if required) are in position and oriented correctly. See the “**Barrel and Brackets – Ring Attachment**” section. On tube motor operated grilles with stamped rings, the ring that is located between the tube motor fasteners should be shipped with the ring in position. If not, or if you suspect the ring is incorrectly oriented, consult factory. Fasten all rings.

2. Locate the idler bracket and cotter pin. Slide the idler bracket onto the idler end shaft until it clears the 1/8” hole. Insert the provided cotter pin into the 1/8” hole and bend (1) leg along end shaft, as to not interfere with the bearing.
3. Install crank eye kit so that the crank eye is towards the floor. Fasten using the provided hardware.
4. Position the assembly on the ground in the opening so that the mounting holes in the brackets are facing the wall. Use this time to ensure that the Tube Motor is oriented as ordered (LH or RH) and that the hand crank is positioned correctly.
5. Lift the entire assembly so that the top of the bracket is flush with the top of the guides. The center of balance for the assembly will be marked as the ‘Lifting Point’ on the shaft for reference.

### NOTICE

The assembly weight will be biased towards the **operator side**. Use caution when lifting.

6. Move the assembly into position by aligning the mounting holes in the brackets with the holes in the top of the guides.
7. Verify that the shaft is level and tighten the mounting hardware and set screws in the idler bracket bearing.

**Note:** The operator wiring and limit adjustment information is provided with the operator.

**Tip:** The limit adjustment process for the tube motor can be a time-consuming process, as the reduction throughout the motor sometimes necessitates a large number turns on each limit screw to adjust the position of the limit range. It may prove beneficial to familiarize yourself with the process, or prep the limits in-house, in order to minimize installation time spent in the field.

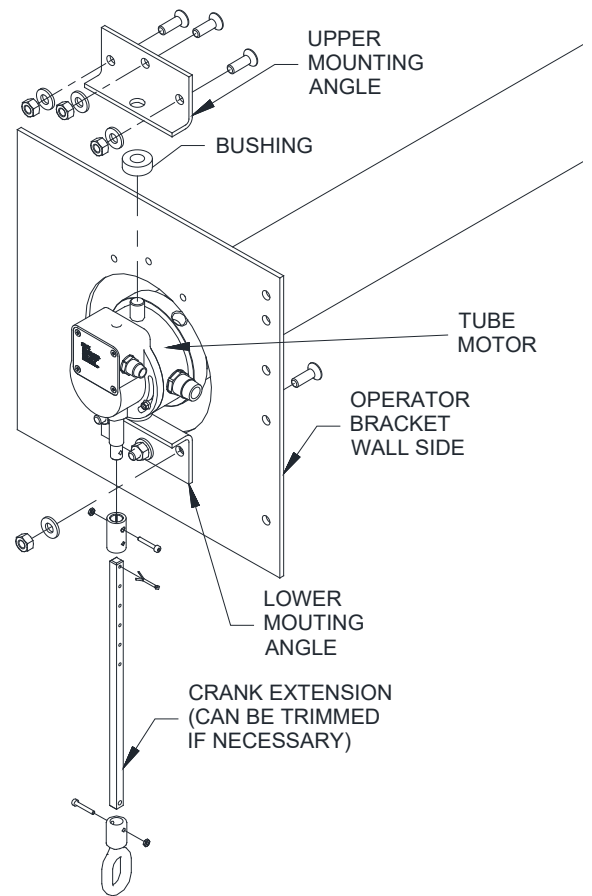

**Figure 12.3 – 4” Shaft Assembly**

- Return to “**Curtain Installation**” once operator installation is completed.